

**SAF® - CPM-15®**  
**FRO®**

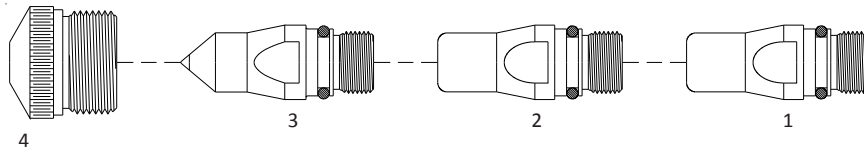

No.	Ref.	Code	Description	Pkg.	No.	Ref.	Code	Description	Pkg.
1	0409-1204	52592	Electrode Air	5	4	0409-1212	51615.12	Tip 60A W000325069	5
2	0409-1205	52593	Electrode N <sub>2</sub>	5		0409-1216	51615.16	Tip 100A W000325072	5
3	0409-1206	52594	Electrode Ar/H	5		0409-1218	51615.18	Tip 150A W000325073	5
4	0409-1210	51615.10	Tip 40A W000325067	5					

**SAF® - CPM-201 / CPM-601®**  
**SAF® - CPM-200 / CPM-250 / CPM-300 / CPM-720®**  
**FRO®**

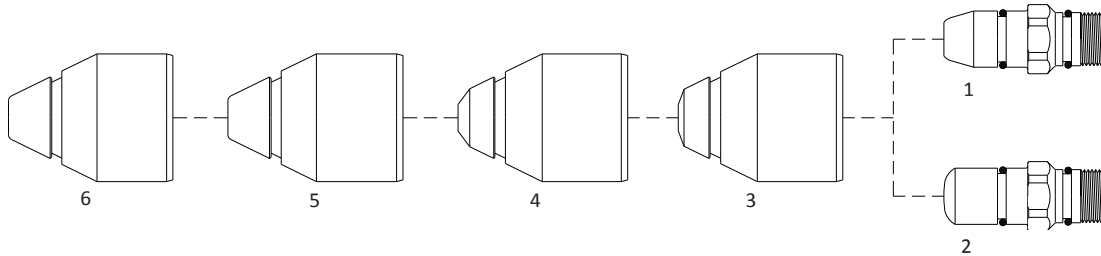

No.	Ref.	Code	Description	Pkg.	No.	Ref.	Code	Description	Pkg.
1	0408-1482	52597	Electrode flat H2	5	5	0409-1278	51605.18	Tip O <sub>2</sub> 150A W000325574	5
	0409-2074	52597W	Electrode flat W2 Tungsten	5		0409-1279	51605.20	Tip O <sub>2</sub> 180A W000325575	5
2	0409-2095	52598	Electrode flat H25	5			51605.22	Tip O <sub>2</sub> 240A W000325084	5
3	0409-2071	51603	Tip O <sub>2</sub> 30A W000325104	5		0409-1280	51605.25	Tip O <sub>2</sub> 250A W000325601	5
4	0409-2072	51604	Tip O <sub>2</sub> 60A W000325105	5	6	0409-1350	51606.30	Tip N <sub>2</sub> 320A W000354417	5
5	0409-2073	51605.13	Tip O <sub>2</sub> 90A W000325106	5		0409-1351	51606.35	Tip N <sub>2</sub> 500A W000354418	5
	0409-2076	51605.16	Tip O <sub>2</sub> 120A W000325108	5		0409-1352	51606.40	Tip N <sub>2</sub> 640A W000354419	5

**SAF® - CPM-360®**  
**140A-260A-360A**

**ON REQUEST**

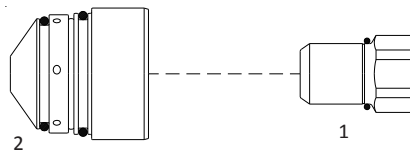

No.	Ref.	Code	Description	Pkg.	No.	Ref.	Code	Description	Pkg.
1	W000120713	52599	Electrode 360A	5	2	W000120712	51711	Tip 260A	5
2	W000120711	51710	Tip 140A	5	2	W000120714	51712	Tip 360A	5

**SAF® - OCP-150®  
 FRO®**

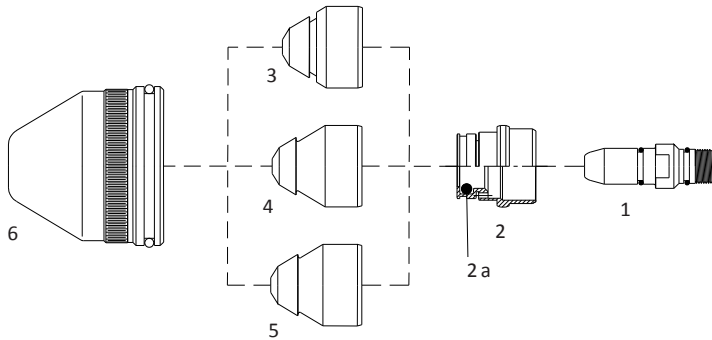

**N<sub>2</sub> plazmagázhoz**

**Ar/H<sub>2</sub> plazmagázhoz**

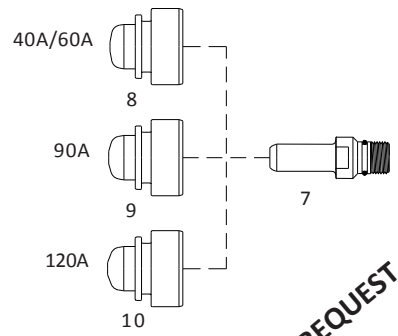

**ON REQUEST**

No.	Ref.	Code	Description	Pkg.	No.	Ref.	Code	Description	Pkg.
1	0409-2194	52596W	Electrode W15, N2 Ar/H <sub>2</sub>	5	5	0409-2249	51708	Tip 90A A90 Ar/H <sub>2</sub>	5
2	0409-2209	60605	Diffusor NL, N2 Ar/H <sub>2</sub>	2		0409-2250	51709	Tip 120A A120 Ar/H <sub>2</sub>	5
2a	0409-2168	60601.41	O-Ring Silicone	20	6	0406-2210	60606	Retaining cap N <sub>2</sub> Ar/H <sub>2</sub>	1
3	0409-2231	51700	Tip 15A N15 N <sub>2</sub>	5	7	0409-2395	52589W	Electrode WT15	5
	0409-2233	51701	Tip 30A N30 N <sub>2</sub>	5	8	0409-2414	51716	Tip 40A - T40 - INOX	5
	0409-2234	51702	Tip 40A N40 N <sub>2</sub>	5		0409-2416	51717	Tip 60A - T60 - INOX	5
	0409-2236	51703	Tip 60A N60 N <sub>2</sub>	5	9	0409-2419	51718	Tip 90A - T90 - INOX	5
4	0409-2239	51705	Tip 90A N90 N <sub>2</sub>	5	10	0409-2420	51719	Tip 120A - T120 - INOX	5
	0409-2240	51706	Tip 120A N120 N <sub>2</sub>	5					

**SAF® - OCP-150®  
 FRO®**

**O<sub>2</sub> plazmagázhoz**

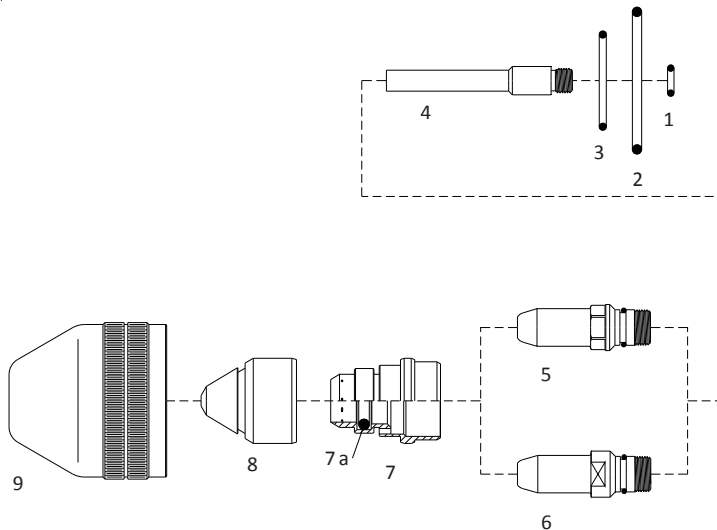

No.	Ref.	Code	Description	Pkg.	No.	Ref.	Code	Description	Pkg.
1	0408-1238	60600.44	O-Ring Nitrile	20	7a	0409-2168	60601.41	O-Ring Silicone	20
2	0408-1282	60600.43	O-Ring Nitrile	20	8	0409-2173	51600.07	Tip 30A	5
3	0408-1284	60600.42	O-Ring Nitrile	20		0409-2174	51600.08	Tip 40A	5
4	0409-2154	60602	Diffusor	1		0409-2176	51600.10	Tip 60A	5
5	0409-2184	52595	Electrode	5		0409-2183	51600.13	Tip 90A	5
6	0409-2185	52596	Electrode - HX5	5		0409-2186	51600.16	Tip 120A	5
7	0409-2170	60601	Swirl ring OCP VD6 60A	2	9	0409-2166	60600	Retaining cap	1
	0409-2169	60603	Swirl ring OCP VD15 120A	2					

Rendeléskor mindenképpen adja meg a gyári termékkódot vagy a cikkszámot